

IGBT / SFRD MODULES



Features:

- MOS - gate
- NPT / SPT / Trench gate technology
- Low off-state current with weak temperature dependence
- High short circuit current resistance
- Built-in freewheeling soft recovery fast diode
- Low internal inductance
- Internal DBC insulation (Al_2O_3 or AlN) between terminals and baseplate
- Copper or AlSiC baseplate

Applications:

- Frequency converters
- DC servomotor and robot control
- DC choppers
- AC motor control
- Induction heating
- Welding
- Uninterruptible power supplies

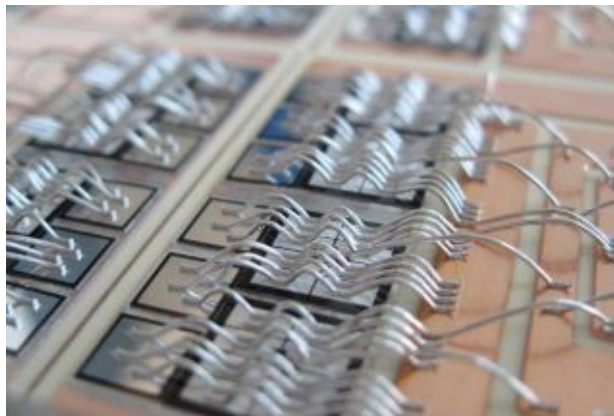
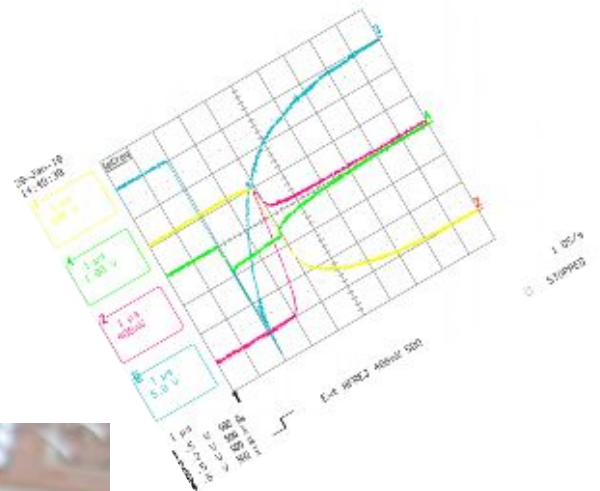

STANDARD IGBT MODULES

Features:

- NPT-technology
- Optimized for middle commutation frequencies

Applications:

- Frequency converters
- Uninterruptible power supplies
- Welding
- Railway auxiliary converters

Type	V_{CES}	I_C	I_{CM}	V_{CESat}	t_{on}	t_{off}	$R_{th(j-c)}$	T_{VJM}	V_{isol}	Case	Circuit
	V	A	A	V	$t_p=1ms$ μs	μs	$^{\circ}C/W$	$^{\circ}C$	V		
Half-bridges											
M2TKI2-50-12	1200	50	100	2.5	0.1	0.45	0.3	150	2500	MI3 w = 165 g	
M2TKI2-75-12	1200	75	150	2.5	0.1	0.52	0.2	150	2500		
M2TKI3-100-12	1200	100	200	2.5	0.21	0.47	0.18	150	2500		
M2TKI2-100-12	1200	100	200	2.5	0.21	0.47	0.16	150	2500	MI4 w = 350 g	
M2TKI2-150-12	1200	150	300	2.5	0.3	0.67	0.1	150	2500		
M2TKI2-200-12	1200	200	400	2.5	0.19	0.63	0.09	150	2500		
M2TKI-300-12	1200	300	600	2.5	0.3	0.67	0.014	150	2500		
M2TKI-400-12	1200	400	800	2.7	0.8	1.15	0.046	150	2500	MI6 w = 1500 g	
M2TKI-600-12	1200	600	1200	2.7	0.8	1.15	0.032	150	2500		
M2TKI-800-12	1200	800	1600	2.7	0.8	1.15	0.025	150	2500		
M2TKI-800-12	1200	800	1600	2.7	0.8	1.15	0.025	150	2500		
Choppers											
MDTKI2-50-12	1200	50	100	2.5	0.1	0.45	0.3	150	2500	MI3 w = 165 g	
MTKID2-50-12	1200	50	100	2.5	0.1	0.45	0.3	150	2500		
MDTKI2-75-12	1200	75	150	2.5	0.1	0.52	0.2	150	2500		
MDTKI2-75-12	1200	75	150	2.5	0.1	0.52	0.2	150	2500	MI4 w = 350 g	
MDTKI2-100-12	1200	100	200	2.5	0.21	0.47	0.16	150	2500		
MTKID2-100-12	1200	100	200	2.5	0.21	0.47	0.16	150	2500		
MDTKI2-150-12	1200	150	300	2.5	0.3	0.67	0.1	150	2500		
MDTKI2-150-12	1200	150	300	2.5	0.3	0.67	0.1	150	2500	MI4 w = 350 g	
MTKID2-150-12	1200	150	300	2.5	0.3	0.67	0.1	150	2500		
MDTKI2-200-12	1200	200	400	2.5	0.19	0.63	0.09	150	2500		
MTKID2-200-12	1200	200	400	2.5	0.19	0.63	0.09	150	2500		
MDTKI-400-12	1200	400	800	2.7	0.8	1.15	0.046	150	2500	MI6 w = 1500 g	
MDTKI-600-12	1200	600	1200	2.7	0.8	1.15	0.032	150	2500		
MDTKI-800-12	1200	800	1600	2.7	0.8	1.15	0.025	150	2500		
MDTKI-800-12	1200	800	1600	2.7	0.8	1.15	0.025	150	2500		
Single switches											
MTKI-50-12	1200	50	100	2.5	0.1	0.45	0.3	150	2500	MI1 w = 25 g	
MTKI-50-12-1	1200	50	100	2.5	0.1	0.45	0.3	150	2500		
MTKI2-200-12	1200	200	400	2.5	0.19	0.63	0.08	150	2500	MI5 w = 350 g	
MTKI2-300-12	1200	300	600	2.5	0.21	0.68	0.05	150	2500		
MTKI2-400-12	1200	400	800	2.5	0.21	0.63	0.045	150	2500		
MTKI-800-12	1200	800	1600	2.7	0.8	1.15	0.023	150	2500	MI7 w = 1500 g	
MTKI-1200-12	1200	1200	2400	2.7	0.8	1.15	0.016	150	2500		
MTKI-1600-12	1200	1600	3200	2.7	0.8	1.15	0.0125	150	2500		
MTKI-1800-12	1200	1800	3600	2.7	0.8	1.15	0.011	150	2500	MI8 w = 2100 g	
MTKI-2400-12	1200	2400	4800	2.7	0.8	1.15	0.01	150	2500		

LOW LOSS IGBT MODULES WITH LOW ON-STATE LOSSES (H series)

Features:





- NPT-technology
- Low saturation V_{CEsat} and forward V_F voltages
- Optimized for low commutation frequencies

Applications:

- Frequency converters
- Uninterruptible power supplies
- Welding
- Railway auxiliary converters

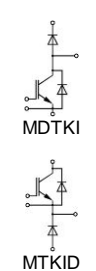
Type	V_{CES}	I_C	I_{CM}	V_{CEsat}	t_{on}	t_{off}	$R_{th(j-c)}$	T_{VJM}	V_{isol}	Case	Circuit
	V	DC A	$t_p=1ms$ A	typ V	typ μs	typ μs	$^{\circ}C/W$	$^{\circ}C$	V		
Half-bridges											
M2TKI-50-06	600	50	100	1.95	0.052	0.151	0.44	150	2500	MI3 w = 165 g	
M2TKI-75-06	600	75	150	1.95	0.09	0.205	0.35	150	2500		
M2TKI-100-06	600	100	200	1.95	0.037	0.18	0.28	150	2500		
M2TKI-150-06	600	150	300	1.95	0.155	0.26	0.21	150	2500		
M2TKI-200-06	600	200	400	1.95	0.229	0.326	0.17	150	2500		
M2TKI-50-12H	1200	50	100	2.1	0.11	0.37	0.27	150	2500		
M2TKI-75-12H	1200	75	150	2.1	0.11	0.42	0.18	150	2500		
M2TKI-100-12-2H	1200	100	200	2.1	0.11	0.48	0.16	150	2500		
M2TKI2-50-17	1700	50	100	2.7	0.2	0.93	0.26	150	4000		
M2TKI2-75-17	1700	75	150	2.7	0.2	0.93	0.2	150	4000		
M2TKI-300-06	600	300	600	1.95	0.176	0.402	0.1	150	2500	MI4 w = 350 g	
M2TKI-400-06	600	400	800	1.95	0.245	0.351	0.085	150	2500		
M2TKI-100-12H	1200	100	200	2.1	0.11	0.48	0.15	150	2500		
M2TKI-150-12H	1200	150	300	2.1	0.13	0.62	0.1	150	2500		
M2TKI-200-12H	1200	200	400	2.1	0.13	0.62	0.09	150	2500		
M2TKI-300-12H	1200	300	600	2.1	0.13	0.62	0.05	150	2500		
M2TKI2-100-17	1700	100	200	2.7	0.2	0.93	0.13	150	4000		
M2TKI2-150-17	1700	150	300	2.7	0.2	0.93	0.1	150	4000		
M2TKI2-200-17	1700	200	400	2.7	0.2	0.93	0.075	150	4000		
M2TKI-400-12H	1200	400	800	2.1	0.46	1.05	0.044	150	2500		
M2TKI-600-12H	1200	600	1200	2.1	0.76	1.09	0.032	150	2500	MI6 w = 1500g	
M2TKI-800-12H	1200	800	1600	2.1	0.46	1.11	0.025	150	2500		
M2TKI-400-17	1700	400	800	2.7	0.44	1.11	0.034	150	4000		
M2TKI-600-17	1700	600	1200	2.7	0.47	1.22	0.026	150	4000		
M2TKI-800-17	1700	800	1600	2.7	0.5	1.24	0.02	150	4000		
Choppers											
MDTKI2-200-06	600	200	400	1.95	0.229	0.326	0.17	150	2500	MI3 w = 165 g	
MTKID2-200-06	600	200	400	1.95	0.229	0.326	0.17	150	2500		
MDTKI-50-12H	1200	50	100	2.1	0.11	0.37	0.27	150	2500		
MTKID-50-12H	1200	50	100	2.1	0.11	0.37	0.27	150	2500		
MDTKI-75-12H	1200	75	150	2.1	0.11	0.42	0.18	150	2500		
MTKID-75-12H	1200	75	150	2.1	0.11	0.42	0.18	150	2500		
MDTKI-100-12-2H	1200	100	200	2.1	0.11	0.48	0.16	150	2500		
MTKID-100-12-2H	1200	100	200	2.1	0.11	0.48	0.16	150	2500		
MDTKI2-50-17	1700	50	100	2.7	0.2	0.93	0.26	150	4000		
MTKID2-50-17	1700	50	100	2.7	0.2	0.93	0.26	150	4000		
MDTKI2-75-17	1700	75	150	2.7	0.2	0.93	0.2	150	4000		
MTKID2-75-17	1700	75	150	2.7	0.2	0.93	0.2	150	4000		
MDTKI2-200-17	1700	200	400	2.7	0.2	0.93	0.075	150	4000		
MTKID2-200-17	1700	200	400	2.7	0.2	0.93	0.075	150	4000		

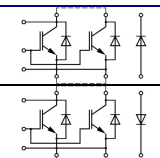
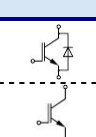
LOW LOSS IGBT MODULES WITH LOW ON-STATE LOSSES (H series)

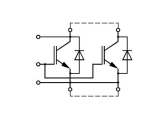
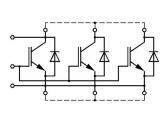
Type	V_{CES}	I_C	I_{CM}	V_{CEsat}	t_{on}	t_{off}	$R_{th(j-c)}$	T_{VJM}	V_{isol}	Case	Circuit
	V	DC A	$t_p=1ms$ A	typ V	typ μs	typ μs	$^{\circ}C/W$	$^{\circ}C$	V		
Choppers											
MDTKI-100-12H	1200	100	200	2.1	0.11	0.48	0.15	150	2500	MI4 w = 350 g	
MTKID-100-12H	1200	100	200	2.1	0.11	0.48	0.15	150	2500		
MDTKI-150-12H	1200	150	300	2.1	0.13	0.62	0.1	150	2500		
MTKID-150-12H	1200	150	300	2.1	0.13	0.62	0.1	150	2500		
MDTKI-200-12H	1200	200	400	2.1	0.13	0.62	0.09	150	2500		
MTKID-200-12H	1200	200	400	2.1	0.13	0.62	0.09	150	2500		
MDTKI-300-12H	1200	300	600	2.1	0.13	0.62	0.05	150	2500		
MTKID-300-12H	1200	300	600	2.1	0.13	0.62	0.05	150	2500		
MDTKI2-100-17	1700	100	200	2.7	0.2	0.93	0.13	150	4000		
MTKID2-100-17	1700	100	200	2.7	0.2	0.93	0.13	150	4000		
MDTKI2-150-17	1700	150	300	2.7	0.2	0.93	0.1	150	4000		
MTKID2-150-17	1700	150	300	2.7	0.2	0.93	0.1	150	4000		
MDTKI-400-12H	1200	400	800	2.1	0.46	1.05	0.044	150	2500	MI6 w = 1500 g	
MDTKI-600-12H	1200	600	1200	2.1	0.76	1.09	0.032	150	2500		
MDTKI-800-12H	1200	800	1600	2.1	0.46	1.21	0.025	150	2500		
MDTKI-400-17	1700	400	800	2.7	0.44	1.21	0.034	150	4000		
MDTKI-600-17	1700	600	1200	2.7	0.47	1.22	0.026	150	4000		
MDTKI-800-17	1700	800	1600	2.7	0.5	1.24	0.02	150	4000		
MDTKI-1200-17	1700	1200	2400	2.7	0.46	1.24	0.013	150	4000	MI8 w = 2100 g	
MDTKI-1200-17-2	1700	1200	2400	2.7	0.46	1.24	0.013	150	4000		
Single switches											
MTKI-50-06	600	50	100	1.95	0.05	0.13	0.6	150	2500	MI1 w = 25 g	
MTKI-50-12H	1200	50	100	2.1	0.11	0.37	0.27	150	2500		
MTKI-50-12-1H	1200	50	100	2.1	0.11	0.37	0.27	150	2500		
MTKI-200-12H	1200	200	400	2.1	0.19	0.68	0.085	150	2500	MI5 w = 350 g	
MTKI-300-12H	1200	300	600	2.1	0.19	0.68	0.055	150	2500		
MTKI-400-12H	1200	400	800	2.1	0.19	0.68	0.05	150	2500		
MTKI2-200-17	1700	200	400	2.7	0.2	0.93	0.065	150	4000		
MTKI2-300-17	1700	300	600	2.7	0.2	0.93	0.05	150	4000		
MTKI2-400-17	1700	400	800	2.7	0.2	0.93	0.04	150	4000		
MTKI-800-12H	1200	800	1600	2.1	0.45	1.1	0.022	150	2500	MI7 w = 1500 g	
MTKI-1200-12H	1200	1200	2400	2.1	0.75	1.24	0.016	150	2500		
MTKI-1600-12H	1200	1600	3200	2.1	0.49	1.31	0.0125	150	2500		
MTKI-800-17	1700	800	1600	2.7	0.44	1.22	0.017	150	4000		
MTKI-1200-17	1700	1200	2400	2.7	0.46	1.24	0.013	150	4000		
MTKI-1600-17	1700	1600	3200	2.7	0.49	1.36	0.01	150	4000		
MTKI-800-33H	3300	800	1600	3.0	1.75	4.25	0.013	150	6000		
MTKI-3600-06	600	3600	7200	1.95	0.245	0.351	0.01	150	2500	MI8 w = 2100 g	
MTKI-4800-06	600	4800	9600	1.95	0.245	0.351	0.008	150	2500		
MTKI-1800-12H	1200	1800	3600	2.1	0.81	1.35	0.011	150	2500		
MTKI-2400-12H	1200	2400	4800	2.1	0.58	1.39	0.0084	150	2500		
MTKI-1800-17	1700	1800	3600	2.7	0.5	1.46	0.009	150	4000		
MTKI-2400-17	1700	2400	4800	2.7	0.53	1.59	0.007	150	4000		

FAST IGBT MODULES WITH LOW SWITCHING LOSSES (F series)

Features:

- Low turn-on losses E_{on} and turn-off losses E_{off}
- Optimized for commutation frequencies 15÷35 kHz

Applications:

- Frequency converters
- Uninterruptible power supplies
- Induction heating
- Railway auxiliary converters

Type	V_{CES}	I_C	I_{CM}	V_{CESat}	t_{on}	t_{off}	$R_{th(j-c)}$	T_{VJM}	V_{isol}	Case	Circuit
	DC	$t_p=1ms$	typ	typ	typ						
	V	A	A	V	μs	μs					
Half-bridges											
M2TKI-50-12F	1200	50	100	3.2	0.225	0.66	0.27	150	2500	MI3 w = 165 g	
M2TKI-75-12F	1200	75	150	3.2	0.225	0.66	0.22	150	2500		
M2TKI-100-12-2F	1200	100	200	3.2	0.225	0.66	0.09	150	2500		
M2TKI-100-12F	1200	100	200	3.2	0.225	0.66	0.16	150	2500	MI4 w = 350 g	
M2TKI-150-12F	1200	150	300	3.2	0.225	0.66	0.1	150	2500		
M2TKI-200-12F	1200	200	400	3.2	0.225	0.66	0.09	150	2500		
M2TKI-300-12F	1200	300	600	3.2	0.18	0.59	0.064	150	2500		
Single switches											
MTKI-50-12F	1200	50	100	3.2	0.225	0.66	0.3	150	2500	MI1 w = 25 g	
MTKI-50-12-1F	1200	50	100	3.2	0.225	0.66	0.3	150	2500		
MTKI-200-12F	1200	200	400	3.2	0.18	0.59	0.16	150	2500	MI5 w = 350g	
MTKI-300-12F	1200	300	600	3.2	0.18	0.59	0.05	150	2500		
MTKI-400-12F	1200	400	800	3.2	0.18	0.59	0.045	150	2500		
MTKI-800-12F	1200	800	1600	3.2	0.225	0.64	0.023	150	2500	MI7 w = 1500 g	
MTKI-1200-12F	1200	1200	2400	3.2	0.225	0.64	0.016	150	2500		
MTKI-1800-12F	1200	1800	3600	3.2	0.225	0.64	0.011	150	2500	MI8 w = 2100 g	

HIGH FREQUENCY IGBT MODULES WITH SCHOTTKY DIODES (FS-series)

Features:

- Commutation frequency up to 50 kHz
- Low turn-on losses E_{on}
- Tiny recovery charge of diode Q_{rr}

Applications:

- Induction heating
- High frequency converters
- High frequency modulators



Type	V_{CES}	I_C	$I_{GE(th)}$	I_F/I_{FC}	V_{CESat}	V_F	$R_{th(j-c)}$	T_{VJM}	V_{isol}	Case	Circuit
	DC	$I_{GE(th)}$									
	V	A									
Half-bridges											
M2TKI-50-12FS	1200	50	4.5-6.5	50	3.2	1.5	0.3	150	2500	MI3 w = 165 g	
Choppers											
MDTKI-50-12ES	1200	50	4.5-6.5	50	3.2	1.5	0.3	150	2500	MI3 w = 165 g	
MTKID-50-12-1FS	1200	50	4.5-6.5	50	3.2	1.5	0.3	150	2500		

TRENCH GATE IGBT MODULES (K series)

Features:

- IGBT of IV generation with vertical channels (Trench gate)
- Ultra low on-state losses

Applications:

- Frequency converters
- Uninterruptible power supplies
- Railway auxiliary converters



Type	V _{CES}	I _C	I _{CM}	V _{CESat}	t _{on}	t _{off}	R _{th(j-c)}	T _{VJM}	V _{isol}	Case	Circuit
	V	DC	t _p =1ms	typ	typ	typ					
Half-bridges											
M2TKI-50-12K	1200	50	100	1.7	0.315	0.61	0.4	150	2500	MI3 w = 165 g	
M2TKI-75-12K	1200	75	150	1.7	0.33	0.61	0.3	150	2500		
M2TKI-100-12K	1200	100	200	1.7	0.33	0.61	0.21	150	2500		
M2TKI-150-12K	1200	150	300	1.7	0.4	0.83	0.16	150	2500	MI4 w = 350 g	
M2TKI-200-12K	1200	200	400	1.7	0.4	0.83	0.12	150	2500		
M2TKI-300-12K	1200	300	600	1.7	0.4	0.83	0.085	150	2500		
M2TKI-150-17K	1700	150	300	2.0	0.43	1.20	0.16	150	4000		
M2TKI-300-17K	1700	300	600	2.0	0.43	1.20	0.085	150	4000	MI6 w = 1500 g	
M2TKI-600-12K	1200	600	1200	1.7	0.88	1.14	0.044	150	2500		
M2TKI-800-12K	1200	800	1600	1.7	0.88	1.14	0.032	150	2500		
M2TKI-1200-12K	1200	1200	2400	1.7	0.88	1.14	0.025	150	2500		
M2TKI-800-17K	1700	800	1600	2.0	0.90	1.90	0.028	150	4000		
Choppers											
MDTKI-50-12K	1200	50	100	1.7	0.315	0.61	0.4	150	2500	MI3 w = 165 g	
MTKID-50-12K	1200	50	100	1.7	0.315	0.61	0.4	150	2500		
MDTKI-75-12K	1200	75	150	1.7	0.33	0.61	0.3	150	2500		
MTKID-75-12K	1200	75	150	1.7	0.33	0.61	0.3	150	2500	MI4 w = 350 g	
MDTKI-100-12K	1200	100	200	1.7	0.33	0.61	0.21	150	2500		
MTKID-100-12K	1200	100	200	1.7	0.33	0.61	0.21	150	2500		
MDTKI-150-12K	1200	150	300	1.7	0.4	0.83	0.16	150	2500		
MTKID-150-12K	1200	150	300	1.7	0.4	0.83	0.16	150	2500	MI6 w = 1500 g	
MDTKI-200-12K	1200	200	400	1.7	0.4	0.83	0.12	150	2500		
MTKID-200-12K	1200	200	400	1.7	0.4	0.83	0.12	150	2500		
MDTKI-300-12K	1200	300	600	1.7	0.4	0.83	0.085	150	2500		
MTKID-300-12K	1200	300	600	1.7	0.4	0.83	0.085	150	2500	MI4 w = 350 g	
MDTKI-150-17K	1700	150	300	2.0	0.43	1.20	0.16	150	4000		
MTKID-150-17K	1700	150	300	2.0	0.43	1.20	0.16	150	4000		
MDTKI-300-17K	1700	300	600	2.0	0.43	1.20	0.085	150	4000		
MTKID-300-17K	1700	300	600	2.0	0.43	1.20	0.085	150	4000	MI6 w = 1500 g	
MDTKI-600-12K	1200	600	1200	1.7	0.88	1.14	0.044	150	2500		
MDTKI-800-12K	1200	800	1600	1.7	0.88	1.14	0.032	150	2500		
MDTKI-1200-12K	1200	1200	2400	1.7	0.88	1.14	0.025	150	2500		
MDTKI-800-17K	1700	800	1600	2.0	0.90	1.90	0.028	150	4000		
Single switches											
MTKI-300-12K	1200	300	600	1.7	0.395	0.83	0.085	150	2500	MI5 w = 350 g	
MTKI-400-12K	1200	400	800	1.7	0.395	0.83	0.055	150	2500		
MTKI-600-12K	1200	600	1200	1.7	0.395	0.83	0.045	150	2500		
MTKI-600-17K	1700	600	1200	2.0	0.43	1.23	0.040	150	4000		
MTKI-1200-12K	1200	1200	2400	1.7	0.87	1.14	0.022	150	2500	MI7 w = 1500 g	
MTKI-1600-12K	1200	1600	3200	1.7	0.88	1.14	0.016	150	2500		
MTKI-2400-12K	1200	2400	4800	1.7	0.88	1.14	0.0125	150	2500		
MTKI-1200-17K	1700	1200	2400	2.0	0.90	1.90	0.017	150	4000		
MTKI-1600-17K	1700	1600	3200	2.0	0.90	1.90	0.014	150	4000	MI8 w = 2100 g	
MTKI-3600-12K	1200	3600	9600	1.7	0.88	1.14	0.008	150	2500		
MTKI-2400-17K	1700	2400	4800	2.0	0.90	1.90	0.009	150	4000		

IGBT MODULES WITH HIGH THERMAL CYCLES CAPABILITY (T series)

Features:

- High thermal cycles capability
- AlSiC base plate
- Internal insulation (AIN DBC)

Applications:

- Transport
- High power high voltage drives with cycle operations



Type	V _{CES}	I _C	I _{CM}	V _{CEsat}	t _{on}	t _{off}	R _{th(j-c)}	T _{VJM}	V _{isol}	Case	Circuit
	V	DC A	t _p =1ms A	typ V	typ μs	typ μs					
Half-bridges											
M2TKI-150-12KT	1200	150	300	1.7	0.4	0.83	0.18	150	2500	MI4 w = 300 g	
M2TKI-200-12KT	1200	200	400	1.7	0.4	0.83	0.13	150	2500		
M2TKI-300-12KT	1200	300	600	1.7	0.4	0.83	0.095	150	2500		
M2TKI-150-17KT	1700	150	300	2.0	0.43	1.20	0.18	150	4000		
M2TKI-300-17KT	1700	300	600	2.0	0.43	1.20	0.095	150	4000		
M2TKI-600-12KT	1200	600	1200	1.7	0.88	1.14	0.036	150	2500	MI6 w = 1100 g	
M2TKI-800-12KT	1200	800	1600	1.7	0.88	1.14	0.028	150	2500		
M2TKI-400-17T	1700	400	800	2.7	0.34	1.21	0.034	150	4000		
M2TKI-600-17T	1700	600	1200	2.7	0.47	1.22	0.026	150	4000		
M2TKI-800-17T	1700	800	1600	2.7	0.5	1.24	0.02	150	4000		
M2TKI-800-17KT	1700	800	1600	2.0	0.90	1.90	0.025	150	4000		
Choppers											
MDTKI-600-12KT	1200	600	1200	1.7	0.88	1.14	0.036	150	2500	MI6 w = 1100 g	
MDTKI-800-12KT	1200	800	1600	1.7	0.88	1.14	0.028	150	2500		
MDTKI-400-17T	1700	400	800	2.7	0.34	1.21	0.034	150	4000		
MDTKI-600-17T	1700	600	1200	2.7	0.47	1.22	0.026	150	4000		
MDTKI-800-17T	1700	800	1600	2.7	0.5	1.24	0.020	150	4000		
MDTKI-800-17KT	1700	800	1600	2.0	0.90	1.90	0.025	150	4000		
MDTKI-1200-17T	1700	1200	2400	2.7	0.46	1.24	0.013	150	4000	MI8 w = 1600 g	
MDTKI-1200-17-2T	1700	1200	2400	2.7	0.46	1.24	0.013	150	4000		
Single switches											
MTKI-1200-12KT	1200	1200	2400	1.7	0.87	1.14	0.019	150	2500	MI7 w = 1100 g	
MTKI-1600-12KT	1200	1600	3200	1.7	0.88	1.14	0.013	150	2500		
MTKI-800-17T	1700	800	1600	2.7	0.44	1.21	0.017	150	4000		
MTKI-1200-17T	1700	1200	2400	2.7	0.46	1.23	0.013	150	4000		
MTKI-1600-17T	1700	1600	3200	2.7	0.49	1.36	0.01	150	4000		
MTKI-1200-17KT	1700	1200	2400	2.0	0.90	1.90	0.014	150	4000		
MTKI-1600-17KT	1700	1600	3200	2.0	0.90	1.90	0.012	150	4000		
MTKI-1800-17T	1700	1800	3600	2.7	0.5	1.45	0.009	150	4000	MI8 w = 1600 g	
MTKI-2400-17T	1700	2400	4800	2.7	0.53	1.69	0.007	150	4000		
MTKI-2400-17KT	1700	2400	4800	2.0	0.90	1.90	0.008	150	4000		

IGBT MODULES WITH HIGH INSULATION VOLTAGE (B series)



Features:

- Low on-state and switching losses
- Soft fast recovery freewheeling diode
- Patent design with insulation voltage up to 15 kV between terminals and base plate

Applications:

- Special converters with series connection of module
- Pulse power supplies with high insulation voltage
- Auxiliary converters for DC locomotives

Type	V _{CES}	I _C	I _{CM}	V _{CESat}	t _{on}	t _{off}	R _{th(j-c)}	T _{VJM}	V _{isol}	Case	Circuit
	DC	t _p =1ms	typ	typ	typ	°C/W					
	V	A	A	V	µs	µs					
Half-bridges											
M2TKI-50-12B	1200	50	100	2.5	0.1	0.45	0.35	150	13000	MI9 w = 370 g	
M2TKI-75-12B	1200	75	150	2.5	0.1	0.52	0.24	150	13000		
M2TKI-100-12B	1200	100	200	2.5	0.21	0.47	0.2	150	13000		
M2TKI-50-17B	1700	50	100	2.7	0.2	0.93	0.3	150	13000		
M2TKI-75-17B	1700	75	150	2.7	0.2	0.93	0.24	150	13000		
M2TKI-100-17B	1700	100	200	2.7	0.2	0.93	0.16	150	13000		
Choppers											
MDTKI-50-12B	1200	50	100	2.5	0.1	0.45	0.35	150	13000	MI9 w = 370 g	
MTKID-50-12B	1200	50	100	2.5	0.1	0.45	0.35	150	13000		
MDTKI-75-12B	1200	75	150	2.5	0.1	0.52	0.24	150	13000		
MTKID-75-12B	1200	75	150	2.5	0.1	0.52	0.24	150	13000		
MDTKI-100-12B	1200	100	200	2.5	0.21	0.47	0.2	150	13000		
MTKID-100-12B	1200	100	200	2.5	0.21	0.47	0.2	150	13000		
MDTKI-50-17B	1700	50	100	2.7	0.2	0.93	0.3	150	13000		
MTKID-50-17B	1700	50	100	2.7	0.2	0.93	0.3	150	13000		
MDTKI-75-17B	1700	75	150	2.7	0.2	0.93	0.24	150	13000		
MTKID-75-17B	1700	75	150	2.7	0.2	0.93	0.24	150	13000		
MDTKI-100-17B	1700	100	200	2.7	0.2	0.93	0.16	150	13000		
MTKID-100-17B	1700	100	200	2.7	0.2	0.93	0.16	150	13000		

COMMON EMITTER CIRCUIT IGBT MODULES

Features: • Two IGBT with common emitter connection in one case

- Applications:**
- DC switches
 - High speed safety systems

Type	V _{CES}	I _C	I _{CM}	V _{CESat}	t _{on}	t _{off}	R _{th(j-c)}	T _{VJM}	V _{isol}	Case	Circuit		
	DC	t _p =1ms	typ	typ	typ	°C/W						°C	V
	V	A	A	V	µs	µs							
Standard IGBT													
M2TKIE-100-12	1200	100	200	2.5	0.3	0.67	0.10	150	2500	MI4 w = 350 g			
M2TKIE-150-12	1200	150	300	2.5	0.3	0.67	0.10	150	2500				
M2TKIE-200-12	1200	200	400	2.5	0.19	0.63	0.09	150	2500				
M2TKIE-300-12	1200	300	600	2.5	0.3	0.80	0.05	150	2500				
LOW LOSS IGBT													
M2TKIE-100-12H	1200	100	200	2.1	0.11	0.48	0.10	150	2500				
M2TKIE-150-12H	1200	150	300	2.1	0.13	0.62	0.10	150	2500				
M2TKIE-200-12H	1200	200	400	2.1	0.13	0.62	0.09	150	2500				
M2TKIE-300-12H	1200	300	600	2.1	0.19	0.65	0.05	150	2500				
FAST IGBT													
M2TKIE-100-12H	1200	100	200	1.9	0.25	0.52	0.15	150	2500				
M2TKIE-150-12H	1200	150	300	1.9	0.17	0.67	0.10	150	2500				
M2TKIE-300-12H	1200	300	600	1.9	0.17	0.86	0.05	150	2500				
TRENCH GATE IGBT													
M2TKIE-150-12K	1200	150	400	1.7	0.4	0.83	0.16	150	2500				
M2TKIE-200-12K	1200	200	400	1.7	0.4	0.83	0.12	150	2500				
M2TKIE-300-12K	1200	300	600	1.7	0.4	0.83	0.09	150	2500				

FAST DIODE MODULES

Features:

- Soft reverse recovery
- Short reverse recovery time
- Low switching losses
- Internal DBC insulation between terminals and baseplate

Applications:

- Opposite and snubber diodes for IGBT
- Demagnetizing diodes for inductive loads
- Control systems for AC motors
- Choppers
- Induction heating
- Uninterruptible power supplies
- Welding



Type	V _{RRM} , V _{RSM}	I _F	I _{FAV}	I _{FSM}	V _{FM}	V ₀	r _t	t _{rr} (di/dt)	R _{th(j-c)}	T _{VJM}	V _{isol}	Case	Circuit
		T _c =80 °C		T _j = 150°C	T _j = 25°C			T = 125°C					
	V	A	A	A	V	V	Ω	μs(A/μs)	°C/W	°C	V		
Half-bridges													
M2DF-32-06	600	50	32	270	1.6	0.9	0.0013	0.12(2900)	0.8	150	2500	MI3-1 w = 154 g	
M2DF-32-12	1200	50	32	430	2.8	1.2	0.022	0.2(800)	0.6	150	2500		
M2DF-32-16	1600	50	32	450	2.6	1.5	0.018	0.4(750)	0.56	150	4000		
M2DF-40-06	600	75	40	360	1.6	0.9	0.0086	0.14(3000)	0.66	150	2500		
M2DF-40-12	1200	75	40	450	2.8	1.2	0.015	0.125(900)	0.5	150	2500		
M2DF-40-16	1600	75	40	540	2.6	1.5	0.012	0.4(1100)	0.47	150	4000		
M2DF2-63-06	600	100	63	540	1.6	0.9	0.0065	0.14(4400)	0.4	150	2500		
M2DF2-63-12	1200	100	63	860	2.8	1.2	0.011	0.3(1000)	0.3	150	2500		
M2DF2-63-16	1600	100	63	990	2.6	1.5	0.009	0.8(1100)	0.28	150	4000		
M2DF2-80-06	600	150	80	720	1.6	0.9	0.0043	0.17(5600)	0.33	150	2500		
M2DF2-80-12	1200	150	80	900	2.8	1.2	0.0073	0.4(1500)	0.25	150	2500		
M2DF2-80-16	1600	150	80	1080	2.6	1.5	0.006	0.9(1600)	0.24	150	4000		
M2DF-100-06	600	150	100	810	1.6	0.9	0.0043	0.17(5600)	0.26	150	2500		
M2DF-100-12	1200	150	100	1300	2.8	1.2	0.0073	0.4(1500)	0.2	150	2500		
M2DF-100-16	1600	150	100	1350	2.6	1.5	0.006	0.9(1600)	0.186	150	4000		
M2DF-125-06	600	225	125	1080	1.6	0.9	0.0029	0.2(4000)	0.22	150	2500		
M2DF-125-12	1200	225	125	1350	2.8	1.2	0.0049	0.5(2000)	0.16	150	2500		
M2DF-125-16	1600	225	125	1620	2.6	1.5	0.004	1.0(2300)	0.16	150	4000		
M2DF-160-06	600	300	160	1440	1.6	0.9	0.0022	0.25(4200)	0.170	150	2500	MI4-1 w = 350 g	
M2DF-200-06	600	300	200	1620	1.6	0.9	0.0022	0.25(4200)	0.130	150	2500		
M2DF2-250-06	600	450	250	2160	1.6	0.9	0.0014	0.25(4200)	0.100	150	2500		
M2DF2-320-06	600	600	320	2880	1.6	0.9	0.001	0.25(3500)	0.083	150	2500		
M2DF-160-12	1200	300	160	1800	2.8	1.2	0.0037	0.55(2500)	0.125	150	2500		
M2DF-200-12	1200	300	200	2610	2.8	1.2	0.0037	0.55(2500)	0.100	150	2500		
M2DF2-250-12	1200	450	250	2700	2.8	1.2	0.0024	0.40(2000)	0.080	150	2500		
M2DF-160-16	1600	300	160	2160	2.6	1.5	0.003	0.70(3400)	0.120	150	4000		
M2DF-200-16	1600	300	200	2700	2.6	1.5	0.003	0.70(3400)	0.090	150	4000		
M2DF2-250-16	1600	450	250	3240	2.6	1.5	0.002	0.70(2800)	0.080	150	4000		
Single diodes													
MDF-32-06	600	50	32	270	1.6	0.9	0.013	0.120(2900)	0.80	150	2500	MI1-1 w = 25 g	
MDF-40-06	600	75	40	360	1.6	0.9	0.0086	0.140(3000)	0.66	150	2500		
MDF-63-06	600	100	63	540	1.6	0.9	0.0065	0.140(4400)	0.40	150	2500		
MDF-32-12	1200	50	32	430	2.8	1.2	0.022	0.200(800)	0.60	150	2500		
MDF-40-12	1200	75	40	450	2.8	1.2	0.015	0.125(900)	0.50	150	2500		
MDF-63-12	1200	100	63	860	2.8	1.2	0.011	0.300(1000)	0.30	150	2500		

FAST DIODE MODULES

Type	V_{RRM}	I_F	I_{FAV}	I_{FSM}	V_{FM}	V_o	r_t	t_{rr} (di/dt) $T = 125^\circ\text{C}$	$R_{th(j-c)}$	T_{VJM}	V_{isol}	Case	Circuit
	V_{RSM}	$T_c = 80^\circ\text{C}$		$T_j = 150^\circ\text{C}$	$T_j = 25^\circ\text{C}$								
	V	A	A	A	V								
Single diodes													
MDF-80-06	600	150	80	720	1.6	0.9	0.0043	0.17(5600)	0.33	150	2500	MI3-1 w = 154 g	
MDF-125-06	600	200	125	1080	1.6	0.9	0.00325	0.20(4000)	0.20	150	2500		
MDF-160-06	600	300	160	1440	1.6	0.9	0.0022	0.25(4200)	0.17	150	2500		
MDF-200-06	600	300	200	1620	1.6	0.9	0.0022	0.25(4200)	0.13	150	2500		
MDF-80-12	1200	150	80	900	2.8	1.2	0.0073	0.40(1500)	0.25	150	2500		
MDF-125-12	1200	200	125	1700	2.8	1.2	0.0055	0.50(2000)	0.15	150	2500		
MDF-160-12	1200	300	160	1800	2.8	1.2	0.0037	0.55(2500)	0.125	150	2500		
MDF-80-16	1600	150	80	1080	2.6	1.5	0.006	0.90(1600)	0.24	150	4000		
MDF-125-16	1600	200	125	1800	2.6	1.5	0.045	1.00(2300)	0.14	150	4000		
MDF-160-16	1600	300	160	2160	2.6	1.5	0.003	0.7(3400)	0.12	150	4000		
MDF-200-12	1200	300	200	2610	2.8	1.2	0.0037	0.55(2500)	0.1	150	2500		
MDF-200-16	1600	300	200	2700	2.6	1.5	0.003	0.7(3400)	0.09	150	4000		
MDF-250-06	600	450	250	2160	1.6	0.9	0.0014	0.25(4200)	0.1	150	2500		
MDF-250-12	1200	450	250	2610	2.8	1.2	0.0024	0.4(2000)	0.083	150	2500		
MDF-250-16	1600	450	250	3240	2.6	1.5	0.002	0.7(2800)	0.08	150	4000		
MDF-320-06	600	600	320	2880	1.6	0.9	0.001	0.25(3500)	0.083	150	2500	MI5-1 w = 350 g	
MDF-320-12	1200	600	320	3600	2.8	1.2	0.0018	0.4(3000)	0.06	150	2500		
MDF-320-16	1600	600	320	4320	2.6	1.5	0.0015	0.6(4200)	0.0625	150	4000		
MDF-400-06	600	600	400	3240	1.6	0.9	0.001	0.25(3500)	0.07	150	2500		
MDF-400-12	1200	600	400	5200	2.8	1.2	0.0018	0.4(3000)	0.05	150	2500		
MDF-500-06	600	900	500	4300	1.6	0.9	0.007	0.3(3500)	0.055	150	2500		
MDF-500-12	1200	900	500	5400	2.8	1.2	0.0012	0.45(3000)	0.04	150	2500		
MDF-500-16	1600	900	500	6480	2.6	1.5	0.001	0.7(4800)	0.04	150	4000		

FAST DIODE MODULES WITH HIGH INSULATION VOLTAGE

Features:

- Low on-state and switching losses
- Soft reverse recovery
- Patent design with insulation voltage up to 15 kV between main and gate terminals and base plate

Applications:

- Special converters with series connection of modules
- High voltage pulse power supplies



Type	V_{RRM}	I_F	I_{FRM}	V_F	I_{rm}	Q_{rr}	T_{VJM}	$R_{th(j-c)}$	V_{isol}	Case	Circuit
	V	A	$t_0 = 1\text{ms}$	typ	typ	typ					
M3DF-400-06B	600	400	800	1.25	3.15	47	150	0.14	13000	MI10-1 w = 2000 g	

OUTLINES

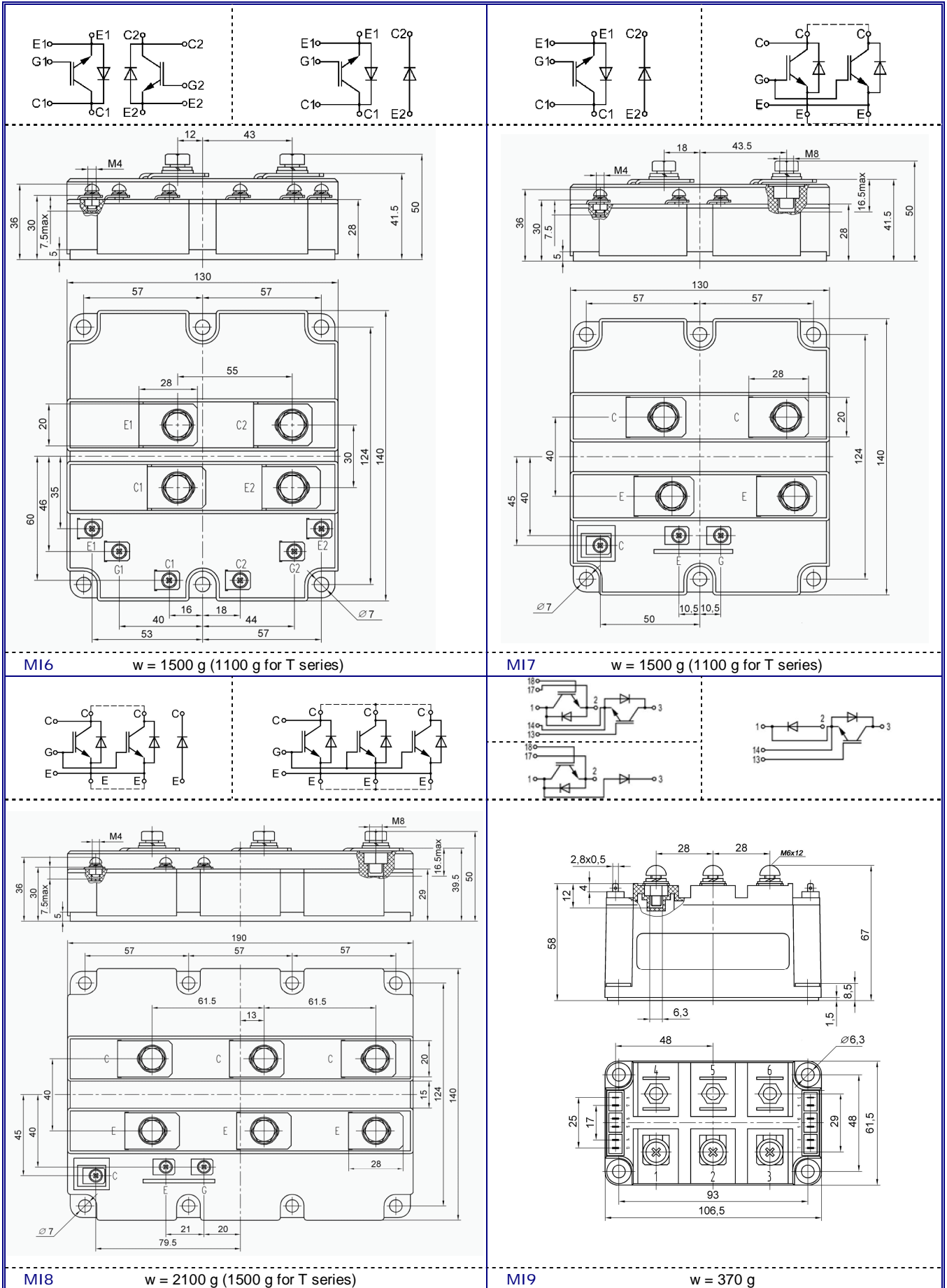

OUTLINES

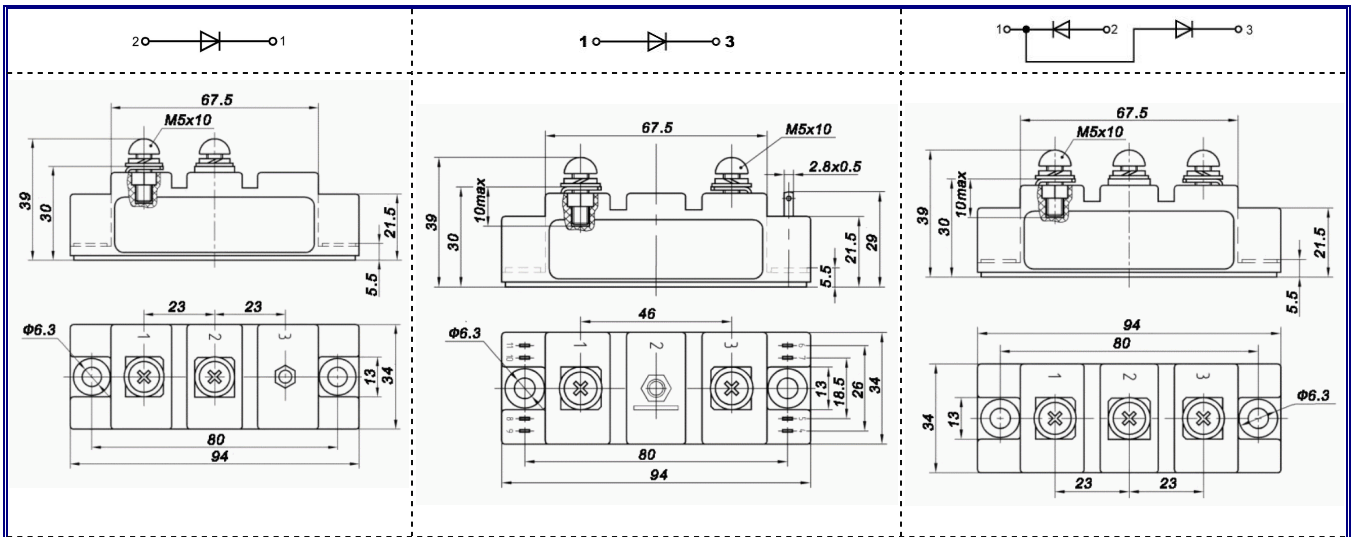

MI3-1

w = 154 g

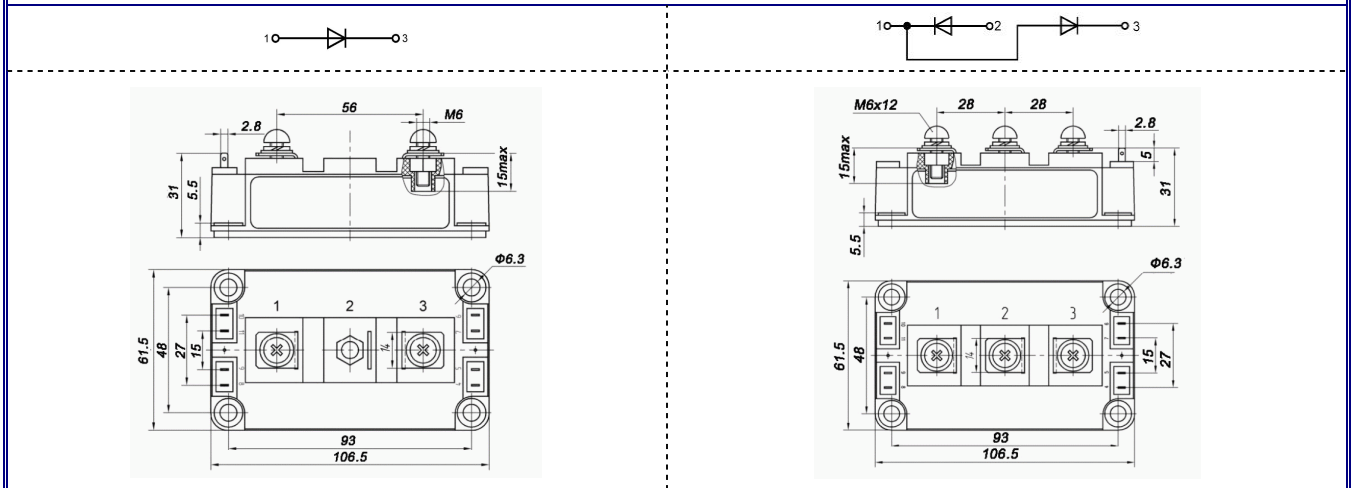

MI4-1

w = 350 g

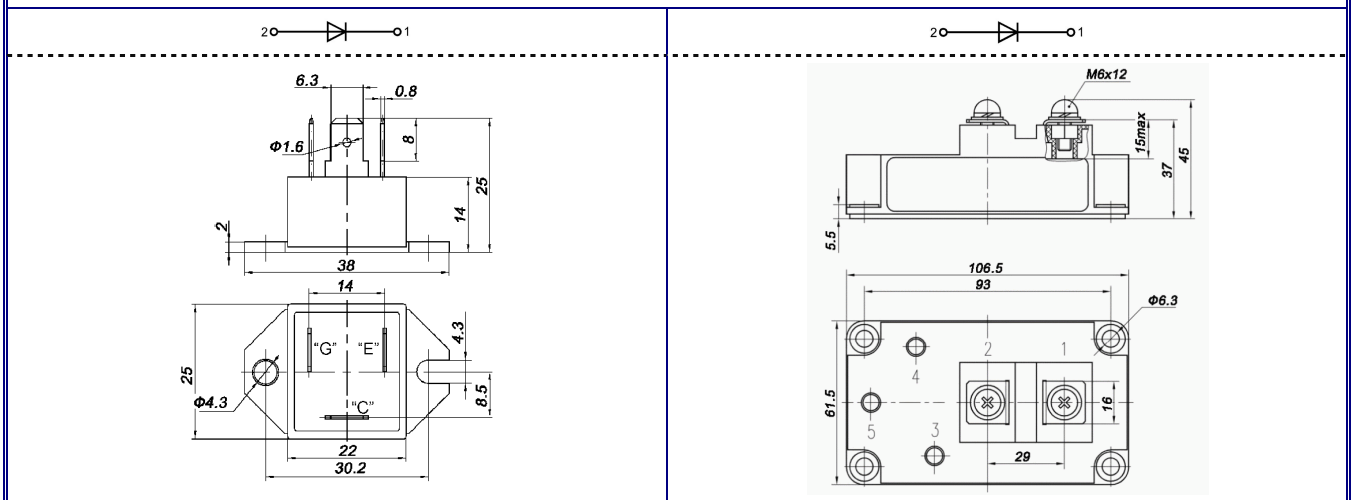

MI1-1

w = 25 g

MI5-1

w = 350 g

OUTLINES

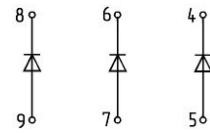
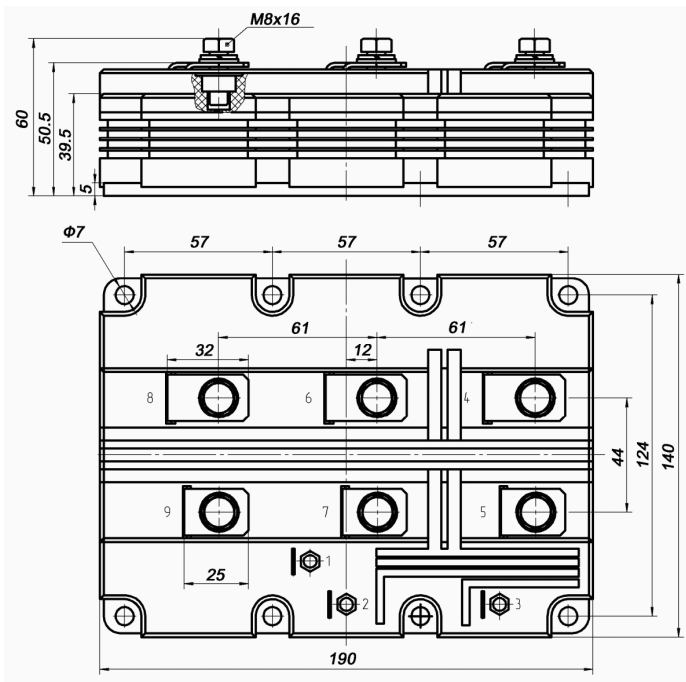

MI10-1

w = 2000 g